



**ETC Laboratories**

**ETC Laboratories**  
**Corporate Offices / Laboratories**  
297 Buell Road  
Rochester, NY 14624  
(585) 328-7668  
Fax: (585) 328-7777

**Simulation Report (Revised)**

Rendered To:

Showcase Custom Vinyl Windows  
1002 Olde Towne Drive  
Irving, TX 75061

**Productline Series/Model**

Series 800 Horizontal Slider Window

**Report Number**

ETC-07-738-19423.1

Report Number: ETC-07-738-19423.1  
 Job Number: ETC-08-738-20621-3  
 Simulation Date: July 10, 2007  
 Report Date: July 10, 2007  
 Expiration Date: July 10, 2011  
 Revision Date: February 19, 2008

### NFRC 100-2004, 200-2004, 500-2004 Simulation Report

Rendered To:

Showcase Custom Vinyl Windows  
 1002 Olde Towne Drive  
 Irving, TX 75061

Product Series/Model	Operating Type	Model Size (mm x mm)
Series 800 Horizontal Slider Window	Horizontal Slider, XX	1500 x 1200

#### Validation Test Unit Description\*

Item	Unit	Value
Frame type	-	VY
Sash type	-	VY
Overall width	in.	59.06
Overall height	in.	47.24
Overall IG nominal thickness	-	0.750
Number of glazing layers	-	2
Glass type	-	Float
Glass 1 thickness	in.	0.118
Glass 2 thickness	in.	0.118
Glass 3 thickness	in.	-
Spacer type	-	A8-D
Gap 1 thickness	in.	0.514
Gap 2 thickness	in.	-
Low-e emissivity	-	0.036
Low-e surface	-	2
IG gap fill	-	AIR
Percent gap fill	-	-

\* No reinforcements.

#### Validation Test Unit U-factor

Item	Unit	Value
Simulated U-Factor	Btu/hr-ft <sup>2</sup> -°F	0.33

Notes: The validation unit was submitted by Showcase Custom Vinyl Windows.

### NFRC 100-2004 (U-factor), 200-2004 (SHGC and VT), and 500-2004 (CR-value) Productline Matrix

Manufacturer Name: Showcase Custom Vinyl Windows  
 Product Series / Model: Series 800 Horizontal Slider Window  
 Operator Type: Horizontal Slider, XX  
 Frame Type: VY  
 Sash Type: VY

Job Number: ETC-08-738-20621-3  
 Sim Lab Code: SETC  
 Model Size (mm x mm) 1500 x 1200  
 Thermal Break Type:

Report Number: ETC-07-738-19423.1

Product Number	Grouping ID Number	Overall IG Thickness	Pane Thickness #[1]	Pane Thickness #[2]	Pane Thickness #[3]	Gap 1	Gap 2	Gap Fill 1	% of Gap fill 1	Gap Fill 2	% of Gap fill 1	Spacer	Emissivity Surface 1	Emissivity Surface 2	Emissivity Surface 3	Emissivity Surface 4	Emissivity Surface 5	Emissivity Surface 6	Tint	C-O-G U-factor	C-O-G SHGC	C-O-G VT	Grid Type	Grid Size	Total Product U-factor	CR - Value	Total Product SHGC	Total Product VT	Additional Comments
001	00	0.750	0.098	0.098		0.553		AIR				A8-D	0.036							0.30	0.37	0.70	N		0.33	54	0.28	0.54	RLE/Clr
	01	0.750	0.098	0.098		0.553		AIR				A8-D	0.036							0.30	0.37	0.70	G	< 1"	0.33	54	0.26	0.48	
	02	0.750	0.098	0.098		0.553		AIR				A8-D	0.036							0.30	0.37	0.70	S	>1"	0.33	54	0.23	0.42	
	03	0.750	0.118	0.118		0.514		AIR				A8-D	0.036							0.30	0.37	0.70	N		0.33	54	0.28	0.53	RLE/Clr
	04	0.750	0.118	0.118		0.514		AIR				A8-D	0.036							0.30	0.37	0.70	G	< 1"	0.33	54	0.26	0.47	
	05	0.750	0.118	0.118		0.514		AIR				A8-D	0.036							0.30	0.37	0.70	S	>1"	0.33	54	0.23	0.42	
002	00	0.750	0.098	0.098		0.553		ARG	90			A8-D	0.036							0.25	0.36	0.70	N		0.30	57	0.28	0.54	RLE/Clr, Arg
	01	0.750	0.098	0.098		0.553		ARG	90			A8-D	0.036							0.25	0.36	0.70	G	< 1"	0.30	57	0.25	0.48	
	02	0.750	0.098	0.098		0.553		ARG	90			A8-D	0.036							0.25	0.36	0.70	S	>1"	0.30	57	0.23	0.42	
	03	0.750	0.118	0.118		0.514		ARG	90			A8-D	0.036							0.25	0.36	0.70	N		0.30	57	0.28	0.53	RLE/Clr, Arg
	04	0.750	0.118	0.118		0.514		ARG	90			A8-D	0.036							0.25	0.36	0.70	G	< 1"	0.30	57	0.25	0.47	
	05	0.750	0.118	0.118		0.514		ARG	90			A8-D	0.036							0.25	0.36	0.70	S	>1"	0.30	57	0.23	0.42	
003	00	0.750	0.197	0.197		0.356		AIR				A8-D	0.036							0.33	0.37	0.68	N		0.36	50	0.28	0.52	RLE/Clr
	01	0.750	0.197	0.197		0.356		AIR				A8-D	0.036							0.33	0.37	0.68	S	>1"	0.36	50	0.23	0.41	
004	00	0.750	0.197	0.197		0.356		AIR				A8-D	0.036							0.33	0.37	0.68	G	< 1"	0.37	50	0.26	0.47	

Report Number: ETC-07-738-19423.1

Product Number	Grouping ID Number	Overall IG Thickness	Pane Thickness #[1]	Pane Thickness #[2]	Pane Thickness #[3]	Gap 1	Gap 2	Gap Fill 1	% of Gap fill 1	Gap Fill 2	% of Gap fill 1	Spacer	Emissivity Surface 1	Emissivity Surface 2	Emissivity Surface 3	Emissivity Surface 4	Emissivity Surface 5	Emissivity Surface 6	Tint	C-O-G U-factor	C-O-G SHGC	C-O-G VT	Grid Type	Grid Size	Total Product U-factor	CR - Value	Total Product SHGC	Total Product VT	Additional Comments
----------------	--------------------	----------------------	---------------------	---------------------	---------------------	-------	-------	------------	-----------------	------------	-----------------	--------	----------------------	----------------------	----------------------	----------------------	----------------------	----------------------	------	----------------	------------	----------	-----------	-----------	------------------------	------------	--------------------	------------------	---------------------

005	00	0.750	0.197	0.197		0.356		ARG	90			A8-D	0.036							0.27	0.36	0.68	N		0.31	54	0.28	0.52	RLE/Clr, Arg
	01	0.750	0.197	0.197		0.356		ARG	90			A8-D	0.036							0.27	0.36	0.68	S	>1"	0.31	54	0.23	0.41	
006	00	0.750	0.197	0.197		0.356		ARG	90			A8-D	0.036							0.27	0.36	0.68	G	< 1"	0.32	54	0.25	0.47	
007	00	0.750	0.118	0.315		0.317		AIR				A8-D	0.036							0.35	0.36	0.68	N		0.37	50	0.28	0.52	RLE/060-Lami
	01	0.750	0.118	0.315		0.317		AIR				A8-D	0.036							0.35	0.36	0.68	S	>1"	0.37	50	0.23	0.41	
	02	0.750	0.118	0.266		0.366		AIR				A8-D	0.036							0.32	0.36	0.68	N		0.37	50	0.28	0.52	RLE/030-Lami
	03	0.750	0.118	0.266		0.366		AIR				A8-D	0.036							0.32	0.36	0.68	S	>1"	0.37	50	0.23	0.41	
	04	0.750	0.118	0.315		0.317		AIR				A8-D	0.036							0.34	0.36	0.67	N		0.37	50	0.28	0.52	RLE/090-Lami
	05	0.750	0.118	0.315		0.317		AIR				A8-D	0.036							0.34	0.36	0.67	S	>1"	0.37	50	0.23	0.41	
008	00	0.750	0.118	0.315		0.317		AIR				A8-D	0.036							0.35	0.36	0.68	G	< 1"	0.38	50	0.25	0.46	
	01	0.750	0.118	0.266		0.366		AIR				A8-D	0.036							0.32	0.36	0.68	G	< 1"	0.38	50	0.25	0.46	
	02	0.750	0.118	0.315		0.317		AIR				A8-D	0.036							0.34	0.36	0.67	G	< 1"	0.38	50	0.25	0.46	
009	00	0.750	0.118	0.315		0.317		ARG	90			A8-D	0.036							0.28	0.36	0.68	N		0.32	54	0.28	0.52	RLE/060-Lami, Arg
	01	0.750	0.118	0.315		0.317		ARG	90			A8-D	0.036							0.28	0.36	0.68	S	>1"	0.32	54	0.23	0.41	
	02	0.750	0.118	0.266		0.366		ARG	90			A8-D	0.036							0.26	0.36	0.68	N		0.32	54	0.28	0.52	RLE/030-Lami, Arg
	03	0.750	0.118	0.266		0.366		ARG	90			A8-D	0.036							0.26	0.36	0.68	S	>1"	0.32	54	0.23	0.41	
	04	0.750	0.118	0.315		0.317		ARG	90			A8-D	0.036							0.28	0.36	0.67	N		0.32	54	0.28	0.52	RLE/090-Lami, Arg
	05	0.750	0.118	0.315		0.317		ARG	90			A8-D	0.036							0.28	0.36	0.67	S	>1"	0.32	54	0.23	0.41	
010	00	0.750	0.118	0.315		0.317		ARG	90			A8-D	0.036							0.28	0.36	0.68	G	< 1"	0.33	54	0.25	0.46	
	01	0.750	0.118	0.266		0.366		ARG	90			A8-D	0.036							0.26	0.36	0.68	G	< 1"	0.33	54	0.25	0.46	

Report Number: ETC-07-738-19423.1

Product Number	Grouping ID Number	Overall IG Thickness	Pane Thickness #[1]	Pane Thickness #[2]	Pane Thickness #[3]	Gap 1	Gap 2	Gap Fill 1	% of Gap fill 1	Gap Fill 2	% of Gap fill 1	Spacer	Emissivity Surface 1	Emissivity Surface 2	Emissivity Surface 3	Emissivity Surface 4	Emissivity Surface 5	Emissivity Surface 6	Tint	C-O-G U-factor	C-O-G SHGC	C-O-G VT	Grid Type	Grid Size	Total Product U-factor	CR - Value	Total Product SHGC	Total Product VT	Additional Comments
----------------	--------------------	----------------------	---------------------	---------------------	---------------------	-------	-------	------------	-----------------	------------	-----------------	--------	----------------------	----------------------	----------------------	----------------------	----------------------	----------------------	------	----------------	------------	----------	-----------	-----------	------------------------	------------	--------------------	------------------	---------------------

	02	0.750	0.118	0.315		0.317		ARG	90			A8-D	0.036							0.28	0.36	0.67	G	< 1"	0.33	54	0.25	0.46	
--	----	-------	-------	-------	--	-------	--	-----	----	--	--	------	-------	--	--	--	--	--	--	------	------	------	---	------	------	----	------	------	--

011	00	0.750	0.098	0.098		0.553		AIR				A8-D	0.042							0.30	0.42	0.73	N		0.33	54	0.32	0.56	EE272/Clr
	01	0.750	0.098	0.098		0.553		AIR				A8-D	0.042							0.30	0.42	0.73	G	< 1"	0.33	54	0.29	0.50	
	04	0.750	0.098	0.098		0.553		AIR				A8-D	0.042							0.30	0.42	0.73	S	>1"	0.33	54	0.26	0.44	
	05	0.750	0.098	0.098		0.553		AIR				A8-D	0.022							0.29	0.28	0.65	N		0.33	54	0.21	0.50	EE366/Clr
	06	0.750	0.098	0.098		0.553		AIR				A8-D	0.022							0.29	0.28	0.65	G	< 1"	0.33	54	0.19	0.45	
	09	0.750	0.098	0.098		0.553		AIR				A8-D	0.022							0.29	0.28	0.65	S	>1"	0.33	54	0.18	0.39	
	10	0.750	0.118	0.118		0.514		AIR				A8-D	0.042							0.30	0.42	0.72	N		0.33	54	0.32	0.55	EE272/Clr
	11	0.750	0.118	0.118		0.514		AIR				A8-D	0.042							0.30	0.42	0.72	G	< 1"	0.33	54	0.29	0.49	
	14	0.750	0.118	0.118		0.514		AIR				A8-D	0.042							0.30	0.42	0.72	S	>1"	0.33	54	0.26	0.43	
	15	0.750	0.118	0.118		0.514		AIR				A8-D	0.022							0.29	0.28	0.65	N		0.33	54	0.22	0.50	EE366/Clr
	16	0.750	0.118	0.118		0.514		AIR				A8-D	0.022							0.29	0.28	0.65	G	< 1"	0.33	54	0.19	0.44	
	19	0.750	0.118	0.118		0.514		AIR				A8-D	0.022							0.29	0.28	0.65	S	>1"	0.33	54	0.18	0.39	
012	00	0.750	0.098	0.098		0.553		ARG	90			A8-D	0.042							0.25	0.42	0.73	N		0.30	57	0.32	0.56	EE272/Clr, Arg
	01	0.750	0.098	0.098		0.553		ARG	90			A8-D	0.042							0.25	0.42	0.73	G	< 1"	0.30	57	0.29	0.50	
	04	0.750	0.098	0.098		0.553		ARG	90			A8-D	0.042							0.25	0.42	0.73	S	>1"	0.30	57	0.26	0.44	
	05	0.750	0.098	0.098		0.553		ARG	90			A8-D	0.022							0.25	0.27	0.65	N		0.30	57	0.21	0.50	EE366/Clr, Arg
	06	0.750	0.098	0.098		0.553		ARG	90			A8-D	0.022							0.25	0.27	0.65	G	< 1"	0.30	57	0.19	0.45	
	09	0.750	0.098	0.098		0.553		ARG	90			A8-D	0.022							0.25	0.27	0.65	S	>1"	0.30	57	0.17	0.39	
	10	0.750	0.118	0.118		0.514		ARG	90			A8-D	0.042							0.25	0.41	0.72	N		0.30	57	0.32	0.55	EE272/Clr, Arg

Report Number: ETC-07-738-19423.1

Product Number	Grouping ID Number	Overall IG Thickness	Pane Thickness #[1]	Pane Thickness #[2]	Pane Thickness #[3]	Gap 1	Gap 2	Gap Fill 1	% of Gap fill 1	Gap Fill 2	% of Gap fill 1	Spacer	Emissivity Surface 1	Emissivity Surface 2	Emissivity Surface 3	Emissivity Surface 4	Emissivity Surface 5	Emissivity Surface 6	Tint	C-O-G U-factor	C-O-G SHGC	C-O-G VT	Grid Type	Grid Size	Total Product U-factor	CR - Value	Total Product SHGC	Total Product VT	Additional Comments
----------------	--------------------	----------------------	---------------------	---------------------	---------------------	-------	-------	------------	-----------------	------------	-----------------	--------	----------------------	----------------------	----------------------	----------------------	----------------------	----------------------	------	----------------	------------	----------	-----------	-----------	------------------------	------------	--------------------	------------------	---------------------

	11	0.750	0.118	0.118		0.514		ARG	90			A8-D	0.042							0.25	0.41	0.72	G	< 1"	<b>0.30</b>	<b>57</b>	<b>0.29</b>	<b>0.49</b>	
	14	0.750	0.118	0.118		0.514		ARG	90			A8-D	0.042							0.25	0.41	0.72	S	>1"	<b>0.30</b>	<b>57</b>	<b>0.26</b>	<b>0.43</b>	
	15	0.750	0.118	0.118		0.514		ARG	90			A8-D	0.022							0.24	0.27	0.65	N		<b>0.30</b>	<b>57</b>	<b>0.21</b>	<b>0.50</b>	EE366/Clr, Arg
	16	0.750	0.118	0.118		0.514		ARG	90			A8-D	0.022							0.24	0.27	0.65	G	< 1"	<b>0.30</b>	<b>57</b>	<b>0.19</b>	<b>0.44</b>	
	19	0.750	0.118	0.118		0.514		ARG	90			A8-D	0.022							0.24	0.27	0.65	S	>1"	<b>0.30</b>	<b>57</b>	<b>0.17</b>	<b>0.39</b>	
013	00	0.750	0.197	0.197		0.356		AIR				A8-D	0.042							0.33	0.41	0.71	N		<b>0.36</b>	<b>50</b>	<b>0.32</b>	<b>0.54</b>	EE272/Clr
	01	0.750	0.197	0.197		0.356		AIR				A8-D	0.042							0.33	0.41	0.71	S	>1"	<b>0.36</b>	<b>50</b>	<b>0.26</b>	<b>0.43</b>	
	02	0.750	0.197	0.197		0.356		AIR				A8-D	0.022							0.32	0.28	0.64	N		<b>0.36</b>	<b>50</b>	<b>0.22</b>	<b>0.49</b>	EE366/Clr
	03	0.750	0.197	0.197		0.356		AIR				A8-D	0.022							0.32	0.28	0.64	S	>1"	<b>0.36</b>	<b>50</b>	<b>0.18</b>	<b>0.38</b>	
014	00	0.750	0.197	0.197		0.356		AIR				A8-D	0.042							0.33	0.41	0.71	G	< 1"	<b>0.37</b>	<b>50</b>	<b>0.29</b>	<b>0.48</b>	
	01	0.750	0.197	0.197		0.356		AIR				A8-D	0.022							0.32	0.28	0.64	G	< 1"	<b>0.37</b>	<b>50</b>	<b>0.20</b>	<b>0.43</b>	
015	00	0.750	0.197	0.197		0.356		ARG	90			A8-D	0.042							0.27	0.41	0.71	N		<b>0.31</b>	<b>54</b>	<b>0.32</b>	<b>0.54</b>	EE272/Clr, Arg
	01	0.750	0.197	0.197		0.356		ARG	90			A8-D	0.042							0.27	0.41	0.71	S	>1"	<b>0.31</b>	<b>54</b>	<b>0.26</b>	<b>0.43</b>	
	02	0.750	0.197	0.197		0.356		ARG	90			A8-D	0.022							0.26	0.28	0.64	N		<b>0.31</b>	<b>54</b>	<b>0.22</b>	<b>0.49</b>	EE366/Clr, Arg
	03	0.750	0.197	0.197		0.356		ARG	90			A8-D	0.022							0.26	0.28	0.64	S	>1"	<b>0.31</b>	<b>54</b>	<b>0.18</b>	<b>0.38</b>	
016	00	0.750	0.197	0.197		0.356		ARG	90			A8-D	0.042							0.27	0.41	0.71	G	< 1"	<b>0.33</b>	<b>54</b>	<b>0.28</b>	<b>0.48</b>	
	01	0.750	0.197	0.197		0.356		ARG	90			A8-D	0.022							0.26	0.28	0.64	G	< 1"	<b>0.33</b>	<b>54</b>	<b>0.20</b>	<b>0.43</b>	
017	00	0.750	0.118	0.315		0.317		AIR				A8-D	0.042							0.35	0.41	0.70	N		<b>0.37</b>	<b>50</b>	<b>0.32</b>	<b>0.54</b>	EE272/060-Lami
	01	0.750	0.118	0.315		0.317		AIR				A8-D	0.042							0.35	0.41	0.70	S	>1"	<b>0.37</b>	<b>50</b>	<b>0.26</b>	<b>0.42</b>	
	02	0.750	0.118	0.266		0.366		AIR				A8-D	0.042							0.32	0.41	0.70	N		<b>0.37</b>	<b>50</b>	<b>0.32</b>	<b>0.54</b>	EE272/030-Lami

Report Number: ETC-07-738-19423.1

Product Number	Grouping ID Number	Overall IG Thickness	Pane Thickness #[1]	Pane Thickness #[2]	Pane Thickness #[3]	Gap 1	Gap 2	Gap Fill 1	% of Gap fill 1	Gap Fill 2	% of Gap fill 1	Spacer	Emissivity Surface 1	Emissivity Surface 2	Emissivity Surface 3	Emissivity Surface 4	Emissivity Surface 5	Emissivity Surface 6	Tint	C-O-G U-factor	C-O-G SHGC	C-O-G VT	Grid Type	Grid Size	Total Product U-factor	CR - Value	Total Product SHGC	Total Product VT	Additional Comments
----------------	--------------------	----------------------	---------------------	---------------------	---------------------	-------	-------	------------	-----------------	------------	-----------------	--------	----------------------	----------------------	----------------------	----------------------	----------------------	----------------------	------	----------------	------------	----------	-----------	-----------	------------------------	------------	--------------------	------------------	---------------------

	03	0.750	0.118	0.266		0.366		AIR				A8-D	0.042							0.32	0.41	0.70	S	>1"	<b>0.37</b>	<b>50</b>	<b>0.26</b>	<b>0.42</b>	
	04	0.750	0.118	0.315		0.317		AIR				A8-D	0.042							0.35	0.41	0.70	N		<b>0.37</b>	<b>50</b>	<b>0.32</b>	<b>0.53</b>	EE272/090-Lami
	05	0.750	0.118	0.315		0.317		AIR				A8-D	0.042							0.35	0.41	0.70	S	>1"	<b>0.37</b>	<b>50</b>	<b>0.26</b>	<b>0.42</b>	
	06	0.750	0.118	0.315		0.317		AIR				A8-D	0.022							0.34	0.28	0.63	N		<b>0.37</b>	<b>50</b>	<b>0.22</b>	<b>0.48</b>	EE366/060-Lami
	07	0.750	0.118	0.315		0.317		AIR				A8-D	0.022							0.34	0.28	0.63	S	>1"	<b>0.37</b>	<b>50</b>	<b>0.18</b>	<b>0.38</b>	
	08	0.750	0.118	0.266		0.366		AIR				A8-D	0.022							0.32	0.28	0.63	N		<b>0.37</b>	<b>50</b>	<b>0.22</b>	<b>0.48</b>	EE366/030-Lami
	09	0.750	0.118	0.266		0.366		AIR				A8-D	0.022							0.32	0.28	0.63	S	>1"	<b>0.37</b>	<b>50</b>	<b>0.18</b>	<b>0.38</b>	
	10	0.750	0.118	0.315		0.317		AIR				A8-D	0.022							0.34	0.28	0.63	N		<b>0.37</b>	<b>50</b>	<b>0.22</b>	<b>0.48</b>	EE366/090-Lami
	11	0.750	0.118	0.315		0.317		AIR				A8-D	0.022							0.34	0.28	0.63	S	>1"	<b>0.37</b>	<b>50</b>	<b>0.18</b>	<b>0.38</b>	
<b>018</b>	<b>00</b>	<b>0.750</b>	<b>0.118</b>	<b>0.315</b>		<b>0.317</b>		<b>AIR</b>				<b>A8-D</b>	<b>0.042</b>							<b>0.35</b>	<b>0.41</b>	<b>0.70</b>	<b>G</b>	<b>&lt;1"</b>	<b>0.39</b>	<b>50</b>	<b>0.29</b>	<b>0.48</b>	
	01	0.750	0.118	0.266		0.366		AIR				A8-D	0.042							0.32	0.41	0.70	G	<1"	<b>0.39</b>	<b>50</b>	<b>0.29</b>	<b>0.48</b>	
	02	0.750	0.118	0.315		0.317		AIR				A8-D	0.042							0.35	0.41	0.70	G	<1"	<b>0.39</b>	<b>50</b>	<b>0.29</b>	<b>0.47</b>	
	03	0.750	0.118	0.315		0.317		AIR				A8-D	0.022							0.34	0.28	0.63	G	<1"	<b>0.39</b>	<b>50</b>	<b>0.20</b>	<b>0.43</b>	
	04	0.750	0.118	0.266		0.366		AIR				A8-D	0.022							0.32	0.28	0.63	G	<1"	<b>0.39</b>	<b>50</b>	<b>0.20</b>	<b>0.43</b>	
	05	0.750	0.118	0.315		0.317		AIR				A8-D	0.022							0.34	0.28	0.63	G	<1"	<b>0.39</b>	<b>50</b>	<b>0.20</b>	<b>0.43</b>	
<b>019</b>	<b>00</b>	<b>0.750</b>	<b>0.118</b>	<b>0.315</b>		<b>0.317</b>		<b>ARG</b>	<b>90</b>			<b>A8-D</b>	<b>0.042</b>							<b>0.28</b>	<b>0.41</b>	<b>0.70</b>	<b>N</b>		<b>0.32</b>	<b>54</b>	<b>0.32</b>	<b>0.54</b>	EE272/060-Lami, Arg
	01	0.750	0.118	0.315		0.317		ARG	90			A8-D	0.042							0.28	0.41	0.70	S	>1"	<b>0.32</b>	<b>54</b>	<b>0.26</b>	<b>0.42</b>	
	02	0.750	0.118	0.266		0.366		ARG	90			A8-D	0.042							0.26	0.41	0.70	N		<b>0.32</b>	<b>54</b>	<b>0.32</b>	<b>0.54</b>	EE272/030-Lami, Arg
	03	0.750	0.118	0.266		0.366		ARG	90			A8-D	0.042							0.26	0.41	0.70	S	>1"	<b>0.32</b>	<b>54</b>	<b>0.26</b>	<b>0.42</b>	
	04	0.750	0.118	0.315		0.317		ARG	90			A8-D	0.042							0.28	0.41	0.70	N		<b>0.32</b>	<b>54</b>	<b>0.32</b>	<b>0.53</b>	EE272/090-Lami, Arg

Report Number: ETC-07-738-19423.1

Product Number	Grouping ID Number	Overall IG Thickness	Pane Thickness #[1]	Pane Thickness #[2]	Pane Thickness #[3]	Gap 1	Gap 2	Gap Fill 1	% of Gap fill 1	Gap Fill 2	% of Gap fill 1	Spacer	Emissivity Surface 1	Emissivity Surface 2	Emissivity Surface 3	Emissivity Surface 4	Emissivity Surface 5	Emissivity Surface 6	Tint	C-O-G U-factor	C-O-G SHGC	C-O-G VT	Grid Type	Grid Size	Total Product U-factor	CR - Value	Total Product SHGC	Total Product VT	Additional Comments
----------------	--------------------	----------------------	---------------------	---------------------	---------------------	-------	-------	------------	-----------------	------------	-----------------	--------	----------------------	----------------------	----------------------	----------------------	----------------------	----------------------	------	----------------	------------	----------	-----------	-----------	------------------------	------------	--------------------	------------------	---------------------

	05	0.750	0.118	0.315		0.317		ARG	90			A8-D	0.042							0.28	0.41	0.70	S	>1"	<b>0.32</b>	<b>54</b>	<b>0.26</b>	<b>0.42</b>	
	06	0.750	0.118	0.315		0.317		ARG	90			A8-D	0.022							0.27	0.28	0.63	N		<b>0.32</b>	<b>54</b>	<b>0.21</b>	<b>0.48</b>	EE366/060-Lami, Arg
	07	0.750	0.118	0.315		0.317		ARG	90			A8-D	0.022							0.27	0.28	0.63	S	>1"	<b>0.32</b>	<b>54</b>	<b>0.18</b>	<b>0.38</b>	
	08	0.750	0.118	0.266		0.366		ARG	90			A8-D	0.022							0.25	0.27	0.63	N		<b>0.32</b>	<b>54</b>	<b>0.21</b>	<b>0.48</b>	EE366/030-Lami, Arg
	09	0.750	0.118	0.266		0.366		ARG	90			A8-D	0.022							0.25	0.27	0.63	S	>1"	<b>0.32</b>	<b>54</b>	<b>0.17</b>	<b>0.38</b>	
	10	0.750	0.118	0.315		0.317		ARG	90			A8-D	0.022							0.27	0.27	0.63	N		<b>0.32</b>	<b>54</b>	<b>0.21</b>	<b>0.48</b>	EE366/090-Lami, Arg
	11	0.750	0.118	0.315		0.317		ARG	90			A8-D	0.022							0.27	0.27	0.63	S	>1"	<b>0.32</b>	<b>54</b>	<b>0.17</b>	<b>0.38</b>	
020	00	0.750	0.118	0.315		0.317		ARG	90			A8-D	0.042							0.28	0.41	0.70	G	<1"	<b>0.34</b>	<b>54</b>	<b>0.29</b>	<b>0.48</b>	
	01	0.750	0.118	0.266		0.366		ARG	90			A8-D	0.042							0.26	0.41	0.70	G	<1"	<b>0.34</b>	<b>54</b>	<b>0.29</b>	<b>0.48</b>	
	02	0.750	0.118	0.315		0.317		ARG	90			A8-D	0.042							0.28	0.41	0.70	G	<1"	<b>0.34</b>	<b>54</b>	<b>0.28</b>	<b>0.47</b>	
	03	0.750	0.118	0.315		0.317		ARG	90			A8-D	0.022							0.27	0.28	0.63	G	<1"	<b>0.34</b>	<b>54</b>	<b>0.19</b>	<b>0.43</b>	
	04	0.750	0.118	0.266		0.366		ARG	90			A8-D	0.022							0.25	0.27	0.63	G	<1"	<b>0.34</b>	<b>54</b>	<b>0.19</b>	<b>0.43</b>	
	05	0.750	0.118	0.315		0.317		ARG	90			A8-D	0.022							0.27	0.27	0.63	G	<1"	<b>0.34</b>	<b>54</b>	<b>0.19</b>	<b>0.43</b>	

Comments : Horizontal Slider window with vinyl frame and sashes.  
 No reinforcements.  
 ARG - Argon with Single Probe filling method.  
 A8-D - Duraseal Spacer - Dual Sealed.  
 N - Products with no internal grids.  
 G (Grid Size: <1") - Products with 0.188" x 0.802" size internal grids.  
 S - Products with 1.121" size simulated divided lites.  
 Low-e: 0.036 - Acclimate RLE 70/36 (Guardian); 0.042 - LoE<sup>2</sup>-272 (Cardinal IG); 0.022 - LoE<sup>3</sup>-366 (Cardinal IG)

Revision History: ETC-07-738-19423.1 - Options 011 - 020 were added.

## Specialty Products

### Series 800 Horizontal Slider Window

Report Number: ETC-07-738-19423.1

	No Dividers	Divider <1"	Divider >1"
SHGC0	0.004	0.007	0.009
SHGC1	0.769	0.688	0.612
VT0	0.000	0.000	0.000
VT1	0.765	0.681	0.602

$$SHGC = SHGC_0 + SHGC_c * (SHGC_1 - SHGC_0)$$

$$VT = VT_0 + VT_c * (VT_1 - VT_0)$$

Where  $SHGC_c$  = Center of Glass Solar Heat Gain Coefficient  
&  $VT_c$  = Center of Glass Visible transmittance

## Modeling Assumptions

1. Grouping Performed: 1) Center-of-Glazing

## Product Description

### Series 800 Horizontal Slider Window

Report Number: ETC-07-738-19423.1

#### Frame:

Size (mm)	1500 x 1200
Material	Vinyl - Rigid
Glazing Method	
Glazing Sealant	

#### Sash (1):

Operation Type	Horizontal Sliding
Material	Vinyl - Rigid
Glazing Method	Exterior Glazed
Glazing Sealant	Silicone

#### Sash (2):

Operation Type	Horizontal Sliding
Material	Vinyl - Rigid
Glazing Method	Exterior Glazed
Glazing Sealant	Silicone

#### Reinforcement Material & Locations:

No reinforcements.

#### Weatherstripping Type and Locations:

Fin pile weatherstripping in all members of both sashes.

#### Others:

ARG - Argon with Single Probe filling method.

A8-D - Duraseal Spacer - Dual Sealed.

Low-e: 0.036 - Acclimate RLE 70/36 (Guardian); 0.042 - LoE<sup>2</sup>-272 (Cardinal IG); 0.022 - LoE<sup>3</sup>-366 (Cardinal IG)

*This report, in its original form contains product drawings and a Bill of Materials.*

Report Number: ETC-07-738-19423.1

## Conditions, Terms, and General Notes Regarding The Simulation

The individual products were simulated in full accordance with NFRC 100-2004, 200-2004 & 500-2004, using NFRC approved programs Window 5.2 and THERM 5.2. All window specifications were received from drawings and bill of materials supplied by the manufacturer. This report may not be reproduced except in full, without the approval of ETC Laboratories. This report relates only to the items simulated. Rounding is per NFRC unit conversion and rounding Policy. **The rating values included in this report are for submittal to an NFRC-licensed IA and not meant to be used directly for labeling purposes.** Only those values identified on a valid Certification Authorization Report (CAR) by an NFRC accredited Inspection Agency (IA) are to be used for labeling purposes.

ETC Laboratories makes no opinions or endorsements regarding this product and its performance. ETC Laboratories letters, reports, its name or insignia or mark are for the exclusive use of the client so named herein and any other use is strictly prohibited. The report, letters and the name of ETC Laboratories, its seal or mark shall not be used in any circumstance to the public or in any advertising.

Limitation of Liability: Due diligence was used in rendering the professional opinion. By acceptance of this report, the client agrees to hold harmless and indemnify ETC Laboratories, Inc. from and against all liability, claims, and demands of any kind whatsoever, which arise out of or in any manner connected with the performance of the work referred to herein.

### FOR ETC LABORATORIES

---

Michael Cooper  
Simulation Technician, NFRC Certified Simulator  
Thermal Simulation Department

---

Gurjinder Singh  
Simulator-in-Responsible Charge, NFRC Certified Simulator  
Thermal Simulation Department



THIS MATERIAL IS PROPRIETARY & CONFIDENTIAL TO VINYL BUILDING PRODUCTS INC. AND SHALL NOT BE REPRODUCED, COPIED OR DISSEMINATED WITHOUT THE EXPRESSED WRITTEN PERMISSION OF VINYL BUILDING PRODUCTS INCORPORATED.

A 008A041

SECTION A-A

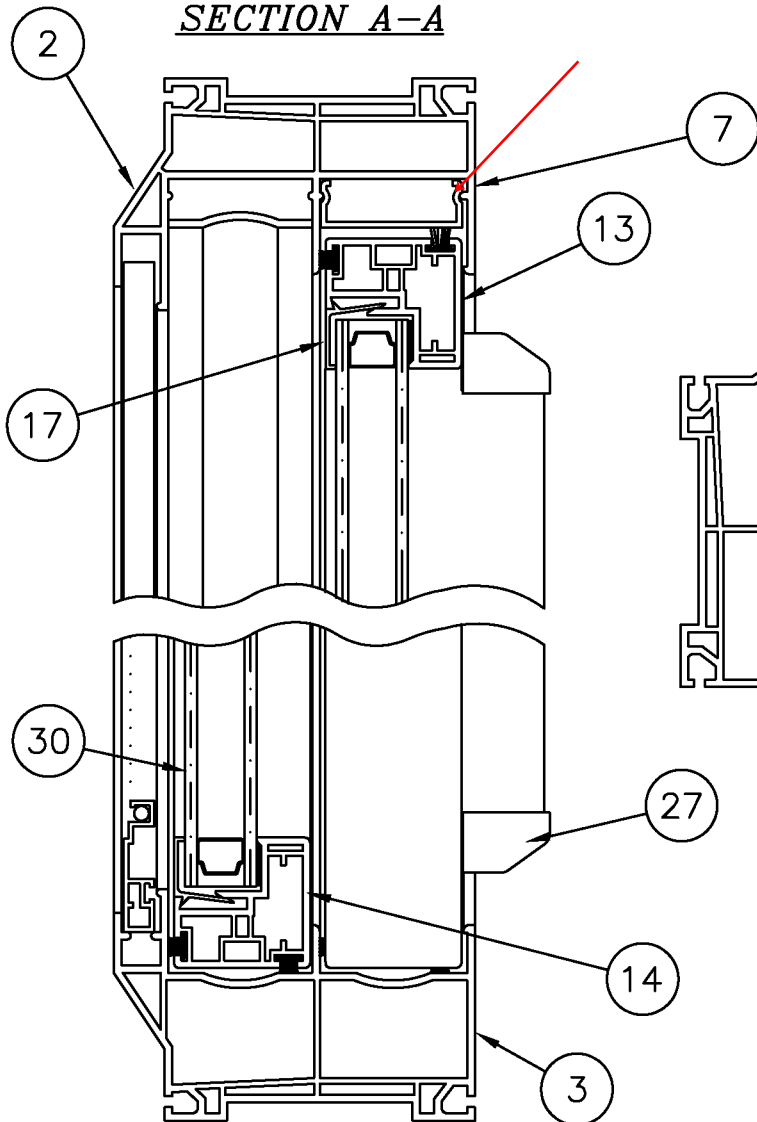

SECTION B-B

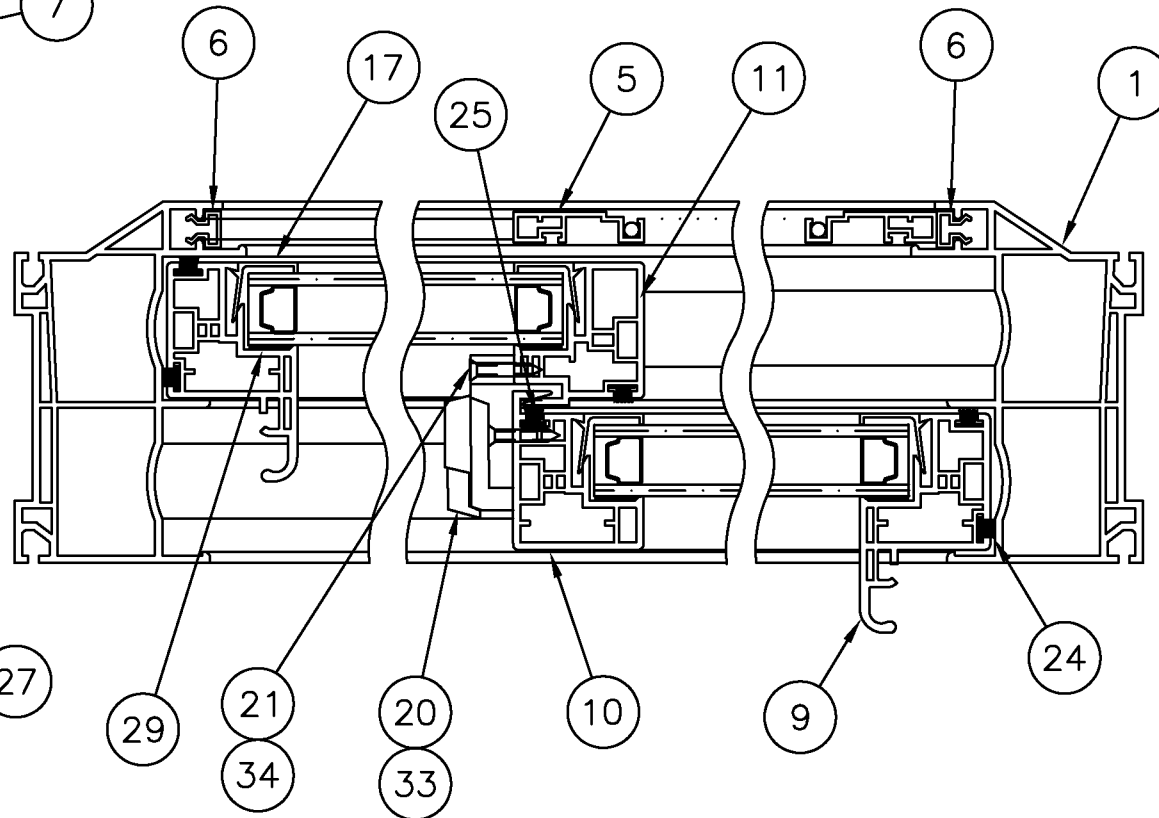

NOTE:

- 1) SCALE: 1=2
- 2) DATE: 11/19/97

*\* 810 HORIZONTAL SLIDER \**  
*\*\* w/ 9000 SERIES SASH \*\**

REV	BY	APPV'D	DATE	CHANGE