



ETC Laboratories

ETC Laboratories
Corporate Offices / Laboratories
297 Buell Road
Rochester, NY 14624
(585) 328-7668
Fax: (585) 328-7777

Simulation Report (Revised)

Rendered To:

Showcase Custom Vinyl Windows
1002 Olde Towne Drive
Irving, TX 75061

Productline Series/Model

Series 200 Picture Window

Report Number

ETC-07-738-19077.2

Report Number: ETC-07-738-19077.2
 Job Number: ETC-08-738-20621-3
 Simulation Date: April 30, 2007
 Report Date: April 30, 2007
 Expiration Date: April 30, 2011
 Revision Date: February 18, 2008

NFRC 100-2004, 200-2004, 500-2004 Simulation Report

Rendered To:

Showcase Custom Vinyl Windows
 1002 Olde Towne Drive
 Irving, TX 75061

Product Series/Model	Operating Type	Model Size (mm x mm)
Series 200 Picture Window	Fixed, O	1200 x 1500

Validation Test Unit Description*

Item	Unit	Value
Frame type	-	VY
Sash type	-	-
Overall width	in.	48.00
Overall height	in.	48.00
Overall IG nominal thickness	-	0.750
Number of glazing layers	-	2
Glass type	-	Float
Glass 1 thickness	in.	0.118
Glass 2 thickness	in.	0.118
Glass 3 thickness	in.	-
Spacer type	-	A8-D
Gap 1 thickness	in.	0.514
Gap 2 thickness	in.	-
Low-e emissivity	-	0.036
Low-e surface	-	2
IG gap fill	-	AIR
Percent gap fill	-	-

* No reinforcements.

Validation Test Unit U-factor

Item	Unit	Value
Simulated U-Factor	Btu/hr-ft ² -°F	0.33

Notes: The validation unit was submitted by Showcase Custom Vinyl Windows.

NFRC 100-2004 (U-factor), 200-2004 (SHGC and VT), and 500-2004 (CR-value) Productline Matrix

Manufacturer Name: Showcase Custom Vinyl Windows
 Product Series / Model: Series 200 Picture Window
 Operator Type: Fixed, O
 Frame Type: VY
 Sash Type:

Job Number: ETC-08-738-20621-3
 Sim Lab Code: SETC
 Model Size (mm x mm) 1200 x 1500
 Thermal Break Type:

Report Number: ETC-07-738-19077.2

Product Number	Grouping ID Number	Overall IG Thickness	Pane Thickness #[1]	Pane Thickness #[2]	Pane Thickness #[3]	Gap 1	Gap 2	Gap Fill 1	% of Gap fill 1	Gap Fill 2	% of Gap fill 1	Spacer	Emissivity Surface 1	Emissivity Surface 2	Emissivity Surface 3	Emissivity Surface 4	Emissivity Surface 5	Emissivity Surface 6	Tint	C-O-G U-factor	C-O-G SHGC	C-O-G VT	Grid Type	Grid Size	Total Product U-factor	CR - Value	Total Product SHGC	Total Product VT	Additional Comments
001	00	0.750	0.118	0.118		0.514		AIR				A8-D	0.036							0.30	0.37	0.70	N		0.33	56	0.31	0.58	RLE/Ctr
	01	0.750	0.118	0.118		0.514		AIR				A8-D	0.036							0.30	0.37	0.70	G	< 1"	0.33	56	0.28	0.52	
	02	0.750	0.118	0.118		0.514		AIR				A8-D	0.036							0.30	0.37	0.70	S	>1"	0.33	56	0.25	0.46	
002	00	0.750	0.118	0.118		0.514		ARG	90			A8-D	0.036							0.25	0.36	0.70	N		0.29	59	0.31	0.58	RLE/Ctr, Arg
	01	0.750	0.118	0.118		0.514		ARG	90			A8-D	0.036							0.25	0.36	0.70	G	< 1"	0.29	59	0.28	0.52	
	02	0.750	0.118	0.118		0.514		ARG	90			A8-D	0.036							0.25	0.36	0.70	S	>1"	0.29	59	0.25	0.46	
003	00	0.750	0.118	0.315		0.317		AIR				A8-D	0.036							0.35	0.36	0.68	N		0.37	52	0.31	0.57	RLE/060-Lami
	01	0.750	0.118	0.315		0.317		AIR				A8-D	0.036							0.35	0.36	0.68	S	>1"	0.37	52	0.25	0.45	
	02	0.750	0.118	0.266		0.366		AIR				A8-D	0.036							0.32	0.36	0.68	N		0.37	52	0.31	0.57	RLE/030-Lami
	03	0.750	0.118	0.266		0.366		AIR				A8-D	0.036							0.32	0.36	0.68	S	>1"	0.37	52	0.25	0.45	
	04	0.750	0.118	0.315		0.317		AIR				A8-D	0.036							0.34	0.36	0.67	N		0.37	52	0.31	0.56	RLE/090-Lami
	05	0.750	0.118	0.315		0.317		AIR				A8-D	0.036							0.34	0.36	0.67	S	>1"	0.37	52	0.25	0.45	
004	00	0.750	0.118	0.315		0.317		AIR				A8-D	0.036							0.35	0.36	0.68	G	< 1"	0.39	52	0.28	0.51	
	01	0.750	0.118	0.266		0.366		AIR				A8-D	0.036							0.32	0.36	0.68	G	< 1"	0.39	52	0.28	0.51	
	02	0.750	0.118	0.315		0.317		AIR				A8-D	0.036							0.34	0.36	0.67	G	< 1"	0.39	52	0.28	0.50	
005	00	0.750	0.118	0.315		0.317		ARG	90			A8-D	0.036							0.28	0.36	0.68	N		0.32	57	0.31	0.57	RLE/060-Lami, Arg
	01	0.750	0.118	0.315		0.317		ARG	90			A8-D	0.036							0.28	0.36	0.68	S	>1"	0.32	57	0.25	0.45	

Report Number: ETC-07-738-19077.2

Product Number	Grouping ID Number	Overall IG Thickness	Pane Thickness #[1]	Pane Thickness #[2]	Pane Thickness #[3]	Gap 1	Gap 2	Gap Fill 1	% of Gap fill 1	Gap Fill 2	% of Gap fill 1	Spacer	Emissivity Surface 1	Emissivity Surface 2	Emissivity Surface 3	Emissivity Surface 4	Emissivity Surface 5	Emissivity Surface 6	Tint	C-O-G U-factor	C-O-G SHGC	C-O-G VT	Grid Type	Grid Size	Total Product U-factor	CR - Value	Total Product SHGC	Total Product VT	Additional Comments
	02	0.750	0.118	0.266		0.366		ARG	90			A8-D	0.036							0.26	0.36	0.68	N		0.32	57	0.31	0.57	RLE/030-Lami, Arg
	03	0.750	0.118	0.266		0.366		ARG	90			A8-D	0.036							0.26	0.36	0.68	S	>1"	0.32	57	0.25	0.45	
	04	0.750	0.118	0.315		0.317		ARG	90			A8-D	0.036							0.28	0.36	0.67	N		0.32	57	0.31	0.56	RLE/090-Lami, Arg
	05	0.750	0.118	0.315		0.317		ARG	90			A8-D	0.036							0.28	0.36	0.67	S	>1"	0.32	57	0.25	0.45	
006	00	0.750	0.118	0.315		0.317		ARG	90			A8-D	0.036							0.28	0.36	0.68	G	<1"	0.34	57	0.28	0.51	
	01	0.750	0.118	0.266		0.366		ARG	90			A8-D	0.036							0.26	0.36	0.68	G	<1"	0.34	57	0.28	0.51	
	02	0.750	0.118	0.315		0.317		ARG	90			A8-D	0.036							0.28	0.36	0.67	G	<1"	0.34	57	0.28	0.50	
007	00	0.750	0.118	0.118		0.514		AIR				A8-D	0.042							0.30	0.42	0.72	N		0.33	55	0.35	0.60	EE272/Clr
	01	0.750	0.118	0.118		0.514		AIR				A8-D	0.042							0.30	0.42	0.72	G	<1"	0.33	55	0.32	0.54	
	02	0.750	0.118	0.118		0.514		AIR				A8-D	0.042							0.30	0.42	0.72	S	>1"	0.33	55	0.29	0.48	
	03	0.750	0.118	0.118		0.514		AIR				A8-D	0.022							0.29	0.28	0.65	N		0.33	55	0.24	0.54	EE366/Clr
	04	0.750	0.118	0.118		0.514		AIR				A8-D	0.022							0.29	0.28	0.65	G	<1"	0.33	55	0.22	0.48	
	05	0.750	0.118	0.118		0.514		AIR				A8-D	0.022							0.29	0.28	0.65	S	>1"	0.33	55	0.20	0.43	
008	00	0.750	0.118	0.118		0.514		ARG	90			A8-D	0.042							0.25	0.41	0.72	N		0.29	59	0.35	0.60	EE272/Clr, Arg
	01	0.750	0.118	0.118		0.514		ARG	90			A8-D	0.042							0.25	0.41	0.72	G	<1"	0.29	59	0.32	0.54	
	02	0.750	0.118	0.118		0.514		ARG	90			A8-D	0.042							0.25	0.41	0.72	S	>1"	0.29	59	0.29	0.48	
	03	0.750	0.118	0.118		0.514		ARG	90			A8-D	0.022							0.24	0.27	0.65	N		0.29	59	0.23	0.54	EE366/Clr, Arg
	04	0.750	0.118	0.118		0.514		ARG	90			A8-D	0.022							0.24	0.27	0.65	G	<1"	0.29	59	0.21	0.48	
	05	0.750	0.118	0.118		0.514		ARG	90			A8-D	0.022							0.24	0.27	0.65	S	>1"	0.29	59	0.19	0.43	
009	00	0.750	0.118	0.315		0.317		AIR				A8-D	0.042							0.35	0.41	0.70	N		0.37	52	0.35	0.59	EE272/060-Lami
	01	0.750	0.118	0.315		0.317		AIR				A8-D	0.042							0.35	0.41	0.70	S	>1"	0.37	52	0.29	0.47	
	02	0.750	0.118	0.266		0.366		AIR				A8-D	0.042							0.32	0.41	0.70	N		0.37	52	0.35	0.59	EE272/030-Lami
	03	0.750	0.118	0.266		0.366		AIR				A8-D	0.042							0.32	0.41	0.70	S	>1"	0.37	52	0.29	0.47	
	04	0.750	0.118	0.315		0.317		AIR				A8-D	0.042							0.35	0.41	0.70	N		0.37	52	0.35	0.58	EE272/090-Lami

Report Number: ETC-07-738-19077.2

Product Number	Grouping ID Number	Overall IG Thickness	Pane Thickness #[1]	Pane Thickness #[2]	Pane Thickness #[3]	Gap 1	Gap 2	Gap Fill 1	% of Gap fill 1	Gap Fill 2	% of Gap fill 1	Spacer	Emissivity Surface 1	Emissivity Surface 2	Emissivity Surface 3	Emissivity Surface 4	Emissivity Surface 5	Emissivity Surface 6	Tint	C-O-G U-factor	C-O-G SHGC	C-O-G VT	Grid Type	Grid Size	Total Product U-factor	CR - Value	Total Product SHGC	Total Product VT	Additional Comments
----------------	--------------------	----------------------	---------------------	---------------------	---------------------	-------	-------	------------	-----------------	------------	-----------------	--------	----------------------	----------------------	----------------------	----------------------	----------------------	----------------------	------	----------------	------------	----------	-----------	-----------	------------------------	------------	--------------------	------------------	---------------------

	05	0.750	0.118	0.315		0.317		AIR				A8-D	0.042							0.35	0.41	0.70	S	>1"	0.37	52	0.28	0.46	
	06	0.750	0.118	0.315		0.317		AIR				A8-D	0.022							0.34	0.28	0.63	N		0.37	52	0.24	0.53	EE366/060-Lami
	07	0.750	0.118	0.315		0.317		AIR				A8-D	0.022							0.34	0.28	0.63	S	>1"	0.37	52	0.20	0.42	
	08	0.750	0.118	0.266		0.366		AIR				A8-D	0.022							0.32	0.28	0.63	N		0.37	52	0.24	0.53	EE366/030-Lami
	09	0.750	0.118	0.266		0.366		AIR				A8-D	0.022							0.32	0.28	0.63	S	>1"	0.37	52	0.20	0.42	
	10	0.750	0.118	0.315		0.317		AIR				A8-D	0.022							0.34	0.28	0.63	N		0.37	52	0.24	0.52	EE366/090-Lami
	11	0.750	0.118	0.315		0.317		AIR				A8-D	0.022							0.34	0.28	0.63	S	>1"	0.37	52	0.20	0.42	
010	00	0.750	0.118	0.315		0.317		AIR				A8-D	0.042							0.35	0.41	0.70	G	<1"	0.39	52	0.32	0.52	
	01	0.750	0.118	0.266		0.366		AIR				A8-D	0.042							0.32	0.41	0.70	G	<1"	0.39	52	0.32	0.53	
	02	0.750	0.118	0.315		0.317		AIR				A8-D	0.042							0.35	0.41	0.70	G	<1"	0.39	52	0.32	0.52	
	03	0.750	0.118	0.315		0.317		AIR				A8-D	0.022							0.34	0.28	0.63	G	<1"	0.39	52	0.22	0.47	
	04	0.750	0.118	0.266		0.366		AIR				A8-D	0.022							0.32	0.28	0.63	G	<1"	0.39	52	0.22	0.47	
	05	0.750	0.118	0.315		0.317		AIR				A8-D	0.022							0.34	0.28	0.63	G	<1"	0.39	52	0.22	0.47	
011	00	0.750	0.118	0.315		0.317		ARG	90			A8-D	0.042							0.28	0.41	0.70	N		0.32	56	0.35	0.59	EE272/060-Lami, Arg
	01	0.750	0.118	0.315		0.317		ARG	90			A8-D	0.042							0.28	0.41	0.70	S	>1"	0.32	56	0.28	0.47	
	02	0.750	0.118	0.266		0.366		ARG	90			A8-D	0.042							0.26	0.41	0.70	N		0.32	56	0.35	0.59	EE272/030-Lami, Arg
	03	0.750	0.118	0.266		0.366		ARG	90			A8-D	0.042							0.26	0.41	0.70	S	>1"	0.32	56	0.28	0.47	
	04	0.750	0.118	0.315		0.317		ARG	90			A8-D	0.042							0.28	0.41	0.70	N		0.32	56	0.35	0.58	EE272/090-Lami, Arg
	05	0.750	0.118	0.315		0.317		ARG	90			A8-D	0.042							0.28	0.41	0.70	S	>1"	0.32	56	0.28	0.46	
	06	0.750	0.118	0.315		0.317		ARG	90			A8-D	0.022							0.27	0.28	0.63	N		0.32	56	0.24	0.53	EE366/060-Lami, Arg
	07	0.750	0.118	0.315		0.317		ARG	90			A8-D	0.022							0.27	0.28	0.63	S	>1"	0.32	56	0.19	0.42	
	08	0.750	0.118	0.266		0.366		ARG	90			A8-D	0.022							0.25	0.27	0.63	N		0.32	56	0.23	0.53	EE366/030-Lami, Arg
	09	0.750	0.118	0.266		0.366		ARG	90			A8-D	0.022							0.25	0.27	0.63	S	>1"	0.32	56	0.19	0.42	
	10	0.750	0.118	0.315		0.317		ARG	90			A8-D	0.022							0.27	0.27	0.63	N		0.32	56	0.23	0.52	EE366/090-Lami, Arg

Report Number: ETC-07-738-19077.2

Product Number	Grouping ID Number	Overall IG Thickness	Pane Thickness #[1]	Pane Thickness #[2]	Pane Thickness #[3]	Gap 1	Gap 2	Gap Fill 1	% of Gap fill 1	Gap Fill 2	% of Gap fill 1	Spacer	Emissivity Surface 1	Emissivity Surface 2	Emissivity Surface 3	Emissivity Surface 4	Emissivity Surface 5	Emissivity Surface 6	Tint	C-O-G U-factor	C-O-G SHGC	C-O-G VT	Grid Type	Grid Size	Total Product U-factor	CR - Value	Total Product SHGC	Total Product VT	Additional Comments
----------------	--------------------	----------------------	---------------------	---------------------	---------------------	-------	-------	------------	-----------------	------------	-----------------	--------	----------------------	----------------------	----------------------	----------------------	----------------------	----------------------	------	----------------	------------	----------	-----------	-----------	------------------------	------------	--------------------	------------------	---------------------

	11	0.750	0.118	0.315		0.317		ARG	90			A8-D	0.022							0.27	0.27	0.63	S	>1"	0.32	56	0.19	0.42	
012	00	0.750	0.118	0.315		0.317		ARG	90			A8-D	0.042							0.28	0.41	0.70	G	< 1"	0.34	56	0.32	0.52	
	01	0.750	0.118	0.266		0.366		ARG	90			A8-D	0.042							0.26	0.41	0.70	G	< 1"	0.34	56	0.32	0.53	
	02	0.750	0.118	0.315		0.317		ARG	90			A8-D	0.042							0.28	0.41	0.70	G	< 1"	0.34	56	0.31	0.52	
	03	0.750	0.118	0.315		0.317		ARG	90			A8-D	0.022							0.27	0.28	0.63	G	< 1"	0.34	56	0.21	0.47	
	04	0.750	0.118	0.266		0.366		ARG	90			A8-D	0.022							0.25	0.27	0.63	G	< 1"	0.34	56	0.21	0.47	
	05	0.750	0.118	0.315		0.317		ARG	90			A8-D	0.022							0.27	0.27	0.63	G	< 1"	0.34	56	0.21	0.47	

Comments : Picture window with vinyl frame.
 No reinforcements.
 ARG - Argon with Single Probe filling method.
 A8-D - Duraseal Spacer - Dual Sealed.
 N - Products with no internal grids.
 G (Grid Size: <1") - Products with 0.188" x 0.802" size internal grids.
 S - Products with 1.121" size simulated divided lites.
 Low-e: 0.036 - Acclimate RLE 70/36 (Guardian); 0.042 - LoE²-272 (Cardinal IG); 0.022 - LoE³-366 (Cardinal IG)

Revision History: ETC-07-738-19077.1 - Options 003 - 006 were added.
 ETC-07-738-19077.2 - Options 007 - 012 were added.

Specialty Products

Series 200 Picture Window

Report Number: ETC-07-738-19077.2

	No Dividers	Divider <1"	Divider >1"
SHGC0	0.006	0.009	0.011
SHGC1	0.840	0.756	0.676
VT0	0.000	0.000	0.000
VT1	0.835	0.747	0.665

$$SHGC = SHGC_0 + SHGC_c * (SHGC_1 - SHGC_0)$$

$$VT = VT_0 + VT_c * (VT_1 - VT_0)$$

Where $SHGC_c$ = Center of Glass Solar Heat Gain Coefficient
& VT_c = Center of Glass Visible transmittance

Modeling Assumptions

1. Grouping Performed: 1) Center-of-Glass

Product Description

Series 200 Picture Window

Report Number: ETC-07-738-19077.2

Frame:

Size (mm)	1200 x 1500
Material	Vinyl - Rigid
Glazing Method	Interior Glazed
Glazing Sealant	Silicone

Sash (1):

Operation Type	_____
Material	_____
Glazing Method	_____
Glazing Sealant	_____

Sash (2):

Operation Type	_____
Material	_____
Glazing Method	_____
Glazing Sealant	_____

Reinforcement Material & Locations:

No reinforcements.

Weatherstripping Type and Locations:

No weatherstripping.

Others:

ARG - Argon with Single Probe filling method.

A8-D - Duraseal Spacer - Dual Sealed.

Low-e: 0.036 - Acclimate RLE 70/36 (Guardian); 0.042 - LoE²-272 (Cardinal IG); 0.022 - LoE³-366 (Cardinal IG)

This report, in its original form contains product drawings and a Bill of Materials.

Report Number: ETC-07-738-19077.2

Conditions, Terms, and General Notes Regarding The Simulation

The individual products were simulated in full accordance with NFRC 100-2004, 200-2004 & 500-2004, using NFRC approved programs Window 5.2 and THERM 5.2. All window specifications were received from drawings and bill of materials supplied by the manufacturer. This report may not be reproduced except in full, without the approval of ETC Laboratories. This report relates only to the items simulated. Rounding is per NFRC unit conversion and rounding Policy. **The rating values included in this report are for submittal to an NFRC-licensed IA and not meant to be used directly for labeling purposes.** Only those values identified on a valid Certification Authorization Report (CAR) by an NFRC accredited Inspection Agency (IA) are to be used for labeling purposes.

ETC Laboratories makes no opinions or endorsements regarding this product and its performance. ETC Laboratories letters, reports, its name or insignia or mark are for the exclusive use of the client so named herein and any other use is strictly prohibited. The report, letters and the name of ETC Laboratories, its seal or mark shall not be used in any circumstance to the public or in any advertising.

Limitation of Liability: Due diligence was used in rendering the professional opinion. By acceptance of this report, the client agrees to hold harmless and indemnify ETC Laboratories, Inc. from and against all liability, claims, and demands of any kind whatsoever, which arise out of or in any manner connected with the performance of the work referred to herein.

FOR ETC LABORATORIES

Michael Cooper
Simulation Technician, NFRC Certified Simulator
Thermal Simulation Department

Gurjinder Singh
Simulator-in-Responsible Charge, NFRC Certified Simulator
Thermal Simulation Department

200 PW	
Location	Part Number
Sash Stop	509-2
Glass stop frame	212
Frame	200MFIN
200MFIN Picture Window	002A159
Glass stop frame	212
Sash Stop	509-2

THIS MATERIAL IS PROPRIETARY & CONFIDENTIAL TO VINYL BUILDING PRODUCTS INC. & SHALL NOT BE REPRODUCED, COPIED OR DISSEMINATED WITHOUT THE EXPRESSED WRITTEN PERMISSION OF VINYL BUILDING PRODUCTS INCORPORATED.

A

002A159

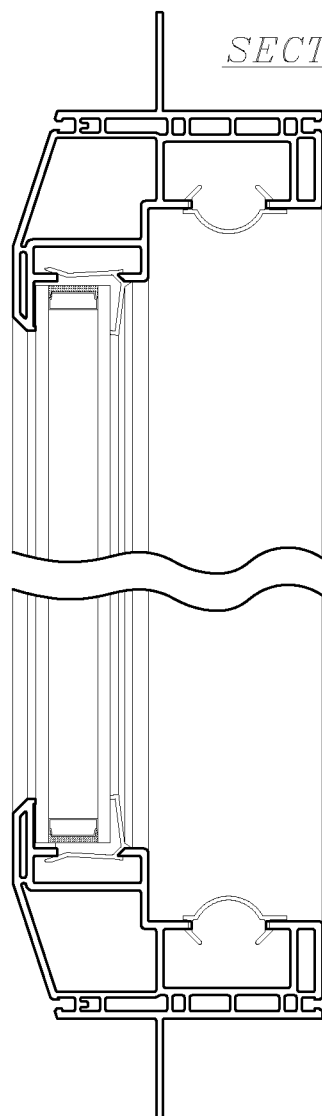

*SECTION *A-A'*

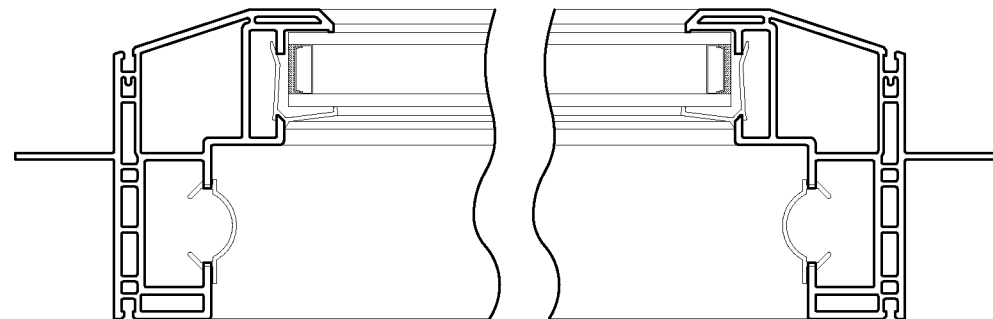

*SECTION *B-B'*

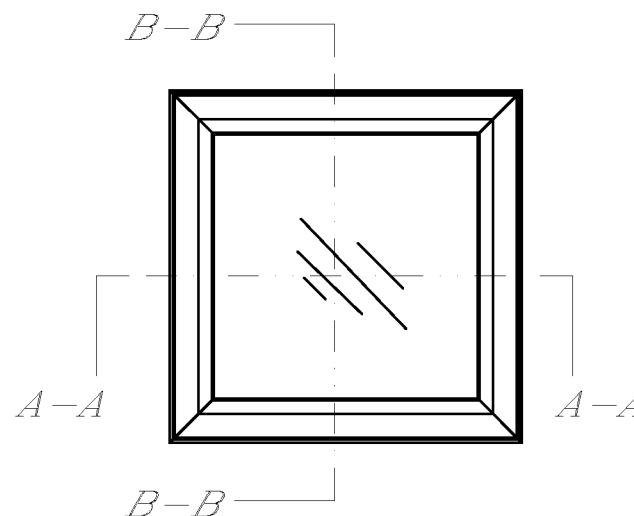

NOTES:

- 1). SEE 200 CUT.XLS FOR CUT FORMULA
- 2). SEE 200 COST.XLS FOR COST SHEET

		© VINYL BUILDING PRODUCTS INC.		
		200 SERIES	TOLERANCES (EXCEPT AS NOTED) DEC: *.010[.25]	
DRAWN SA	DATE 7-26	APPV'D	MAT'L PVC	SCALE 1/2
200MFIN PICTURE WINDOW W/ 509 INSERT, 212 GS			002A159	

REV	BY	APPV'D	DATE	CHANGE
-----	----	--------	------	--------